



Quote 18-May-22
 New Order 18-May-22
FINAL

Ref# 6888

53-3TWWF OT

Revision

CUSTOMER APPLICATION Woodchips

W/O# 6944

DATE: 21-Jun-22

SINGLE SEMI-TRAILER

Designation

ORDER STATUS Final

CUSTOMER NAME	OT Stock	P.O.#	91446-91455
ADDRESS	9076 River Road	DRAWING#	AD-6944-01-V1
CITY	Delta	CONTACT	Will Tucker
PROV/PC STATE/ZIP	B.C. V4G 1B5	DEALER	Ocean Trailer
PHONE	604-940-0210	SHIP VIA	FOB Delhi, ON
FAX	604-940-0610 Toll Free-1-800-891-8858	SALESMAN	
DEPOSIT REQUIRED	Attention Lorraine Genberg		

Qty = 10

(MAY CHANGE, MUST BE CONFIRMED AT TIME OF ORDER)

SERIAL NUMBER'S	Pg 3		PRICING
BASE MODEL	53-3TWWF OT	STYLE	Wedge
Wall CONFIGURATION	Front	to suit wood chip application	Note 7,8
	Sides	to suit wood chip application	Note 7,8
	Rear Door	Van, Solid, Std Galvanized lock rods	
OVERALL LENGTH	53 ft	OVERALL WIDTH	102" Nominal
OVERALL HEIGHT	13' 6" approx.		
KING PIN LOCATION	36" BOLT IN		
UPPER COUPLER	5/16" THK Steel- Set @ 48" High		
	PRIMARY	LIFT or STEERS	
NUMBER OF AXLES	3		
AXLES	5" Round .580 Wall-Tapered Spindle		
AXLE TRACK	77"		
SUSPENSION	Watson TA 30,000		
LOCATION OF SPREADS	see axle layout		
HUB / DRUM ASSEMBLY	10 Stud, Cast Hub / Cast Drum w/long studs		
DISC WHEEL SIZE	8.25 x 22.5		
RIMS	ALUM-LVL1 Mill Inner/Outer		
TIRES	Brand	Goodyear	
	Size	11R22.5 - 41.9 dia	
	Tread	Endurance RSA	
	Ply	14	
	Quantity	12	
AXLE LAYOUT	FRONT-Prim-60-Prim-60-Prim-73-REAR		Sub(1)

CUSTOMER NAME: **OT Stock**

PO 91446-91455

S/N

Pg 3

W/O #

6944

			Note#	PRICING
OIL SEALS	To suit axles			
LUBRICANTS	Oil-Std 80W-90			
BRAKES	ABS	2S2M Meritor Wabco		
	Slack Adj.	Haldex Auto		
	Cam Enclos	All Axles - c/w Dust Shields		
LIFT KITS	None			
LIFT CONTROLS	None			
FRAME WIDTH	48"			
REAR BUMPER	Steel, Flush, Underride		6	
ADDITIONAL BUMPER OPTION #1	None			
ADDITIONAL BUMPER OPTION #2	None			
ADDITIONAL BUMPER OPTION #3	None			
TIRE CARRIER	None			
LANDING GEAR	Holland Mark 5-LGS-2A-113			
TOP RAIL	Titan Tapered, V1			
TOP CROSS TUBE	2 Pcs - 4" OD			
FLOOR CROSSMEMBERS	16" Centers			
KEITH WALKING FLOOR KIT	Running Floor II- 3 1/2" Dia Cylinders-10" stroke			
SLAT MODEL & WIDTH	2190 (1975) 3 1/2" - 1212 Seals T-Blocks Rear			
SLAT WEAR STRIPS	None			
CONTINUOUS BEARING	Continuous Splash/Hold Down Bearings			
SIDE WALL WEAR PLATES	None			
FRONT ACCESS DOOR	None			
TARP STYLE (Tarp form)	Trison installed Black Vinyl Sideroll - rolls open to curbside - West Coast Bungee style		4	
TARP HEADER	Flat-Front & Rear			
TARP BASKET	None			
TARP HOOKS	None			
AXLE FENDER	Titan 1/4" Rolled Aluminum		1	
HYD FITTING	Pressure	1" Quick Coupler-Male		
	Return	1" Quick Coupler-Female		
MUD FLAPS	Style	Titan Black Rubber		
	Location	Mount Mudflaps at rear fender using an angle bracket		
MUD FLAPS - Landing Gear	Yes- 4 Pcs			
PAINT (See Form)	Body- Color	Natural Aluminum		
	Run - Gear	Titan Black		
	Hub / Drum	Same as Running Gear		
	Rims or Disc	Aluminum		
LIGHT PACKAGE (Plug Form)	3 markers per side (includes corner mitre & midturn). At Rear:3 per side 4" dia in lightbar, & 5 rect. at top			
ADDITIONAL LIGHTS' OPTION #1	None			
ADDITIONAL LIGHTS' OPTION #2	None			
ACCESS	Catwalk	STD 24" catwalk	3	
	J-Ladder - Front	Roadside To Catwalk		
	J-Ladder - Rear	Roadside centered between cam locks		
	Steps-Front-Out	None		
	Steps-Front-Ins	None		
	Steps-Rear	Stirrup step roadside, rear, under lightbar, 2" in towards center from end of light bar.		
			Sub(2)	

53-3TWWF OT

Ref#

6888

Pg.3

CUSTOMER NAME: **OT Stock**

PO 91446-91455 S/N

Pg 3

W/O# **6944**

ADDITIONAL SPECIFICATIONS

PRICING

- 1) Add fender support in floor for future *Watson TA250T* suspension located 24" in from rear of trailer. No crossmembers for the 4th axle installed.
- 2) Aluminum tube document holder.
- 3) Ship catwalk inside trailer properly secured (for shipping purposes only), use Drilled holes in frontwall for future catwalk installation.
- 4 a) Trison to install (1) Chain & binder front & rear with (5) cables & West Coast Bungees evenly spaced between. Titan to install tarp hooks, as well as UHMW pads at the joint of each cable and bungee before going to Trison. Trison to add Rubber Wind deflector to front.
- b) Titan to provide storage for crank handle.
- c) Add 2 to 1 Pull rope to tarp
- 5) Add recessed 4" air gauge installed on driverside sidewall. Position air gauge 12" forward of trailer mid length and as high as possible keeping clear of tarping system.
- 6) Prep trailers for future addition of stainless clad rubber bumper blocks

VIN Numbers: Units 1 - 5

VIN Numbers: Unit 6 - 10

PO 91446 - 2TVWF5331PD000867	PO 91451 - 2TVWF5334RD000056
PO 91447 - 2TVWF5333PD000868	PO 91452 - 2TVWF5336RD000057
PO 91448 - 2TVWF5335PD000869	PO 91453 - 2TVWF5338RD000058
PO 91449 - 2TVWF5331PD000870	PO 91454 - 2TVWF533XRD000059
PO 91450 - 2TVWF5333PD000871	PO 91455 - 2TVWF5336RD000060

DATE: **21-Jun-22**

SUBMITTED BY

Customer

Sk 6/16/2022

Date

Sub Total (3)
 Sub Total (2)
 Sub Total (1)
 TOTAL PRICE PER UNIT
 TOTAL COST
 NET COST **CDN\$**

Trailers are sold FOB Delhi, Canada
 Any applicable Federal or Provincial Taxes are not included.

All Applicable Taxes & Licencing Fees Extra

TITAN TRAILERS

PAIN T COLOUR & CODE FORM

CUSTOMER	OT Stock	TITAN WORK ORDER #	6944
DEALER	Ocean Trailer	DEALER WORK ORDER #	
		PURCHASE ORDER #	91446-91455
		UNITS IF APPLICABLE	10
TRAILER TYPE	53-3TWWF OT		

	PAINT COLOUR	PRODUCT NAME	PAINT CODE
Body	Natural Aluminum	None	None
Frame	Natural	None	None
Running Gear	Titan Black	Titan	None

If paint colours are Titan Red, Black or Silver please enter Titan under product name & no code is required.

IF Fully Painted, Thinwall trailers will be painted underneath same as frame & running gear

All Thinwall Trailers that have Body left Natural will receive silver air tanks & silver upper couplers
Dealer or Customer must supply Titan Trailers with required paint codes, product name, colour and a DRY sample of paint. All Two Toned Painted Trailers must have additional detailed written specifications entered above.

Paint Chip Required **No**

Complete Form in Full

<u>Dealer Signature</u>	
<u>Date</u>	

Paint Information needed by this date

Failure to meet this date will delay trailer completion

TITAN TRAILERS WILL NOT BE RESPONSIBLE FOR INCORRECT PAINT SPECIFICATIONS

<u>Office Use Only</u>	
<u>Trailer Sales Department</u>	<u>Date</u>
<u>Signature</u>	

TITAN TRAILERS - TRAILER WIRING SCHEMATICS

1129 Hwy #3, R.R. #3
 Delhi, Ontario
 Canada, N4B 2W6

Wiring Specs

Phone: 519-688-4826
 Fax: 519-688-3083
www.titantrailers.com

53-3TWWF OT

Work Order	6944
P.O. #	91446-91455
Quantity	10

Customer	OT Stock
Dealer	Ocean Trailer
Dealer #	

Main

STD 7-WAY PLUG

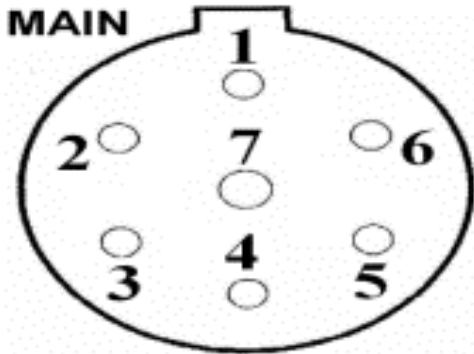

#	COLOUR	FUNCTION
1	WHITE	GROUND
2	BLACK	MARKER & TAILLIGHTS
3	YELLOW	LEFT TURN
4	RED	STOP
5	GREEN	RIGHT TURN
6	BROWN	MARKER & TAILLIGHTS
7	BLUE	ABS

#	COLOUR	FUNCTION
1	WHITE	
2	BLACK	
3	YELLOW	
4	RED	
5	GREEN	
6	BROWN	
7	BLUE	

None

	STANDARD 7-WAY PLUG
	I.S.O. 7-WAY PLUG

Plug Information needed no later that the following date:

Failure to meet this date will delay trailer completion.

Dealer

Signature:

Date:

CONFIGURATION APPROVAL DRAWING

THIS DRAWING CONFIRMS BASIC TRAILER DIMENSIONS; OVERALL HEIGHT, OVERALL LENGTH, PIN SETTING AND AXLE POSITIONS ONLY.
TRAILER OPTIONS MUST BE VERIFIED BY REFERRING TO THE SALES ORDER. ANY DISCREPANCIES MUST BE REPORTED TO TITAN TRAILERS INC.

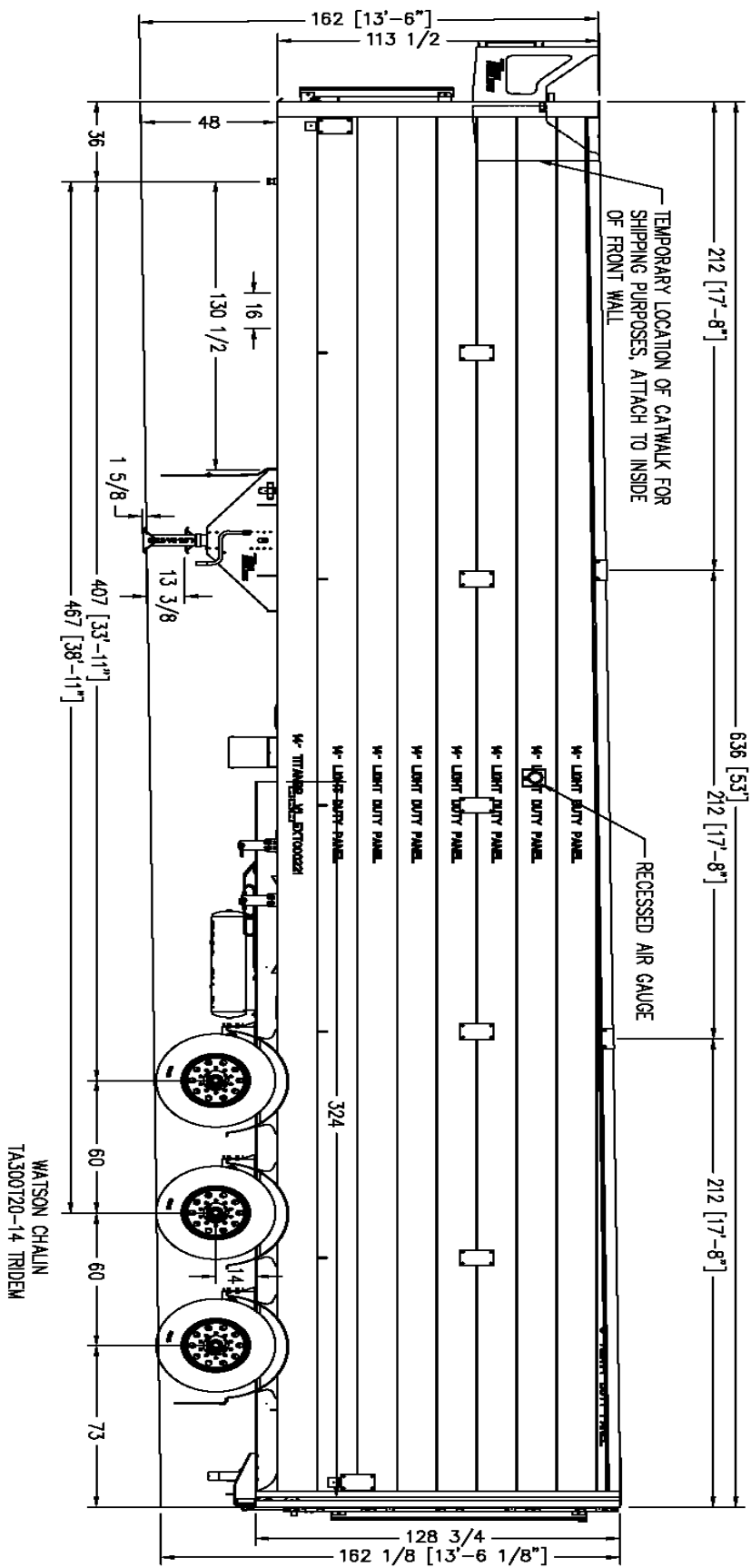

SUSPENSIONS: WATSON CHALIN TAJ3007 SERIES
TIRES: 11R22.5
LANDING GEAR: HOLLAND MARKV LGS-2A-113
VOLUME: 3968 CU FT (147 CU YD)

CUSTOMER: OT Stock
TRAILER: 53' 3-AXLE AWF WEDGED



WOODCHIP APPLICATION

APPROVED BY: [Signature]

NO. NO: 6944

DEALER NO: []

SIGNATURE: [] DATE: []

DEALER IS RESPONSIBLE TO CHECK THAT TRAILER CONFIGURATION SHOWN ON THIS DRAWING CONFORMS TO ALL PROVINCIAL STATE AND/OR FEDERAL REGULATIONS. THIS DRAWING IS THE SOLE PROPERTY OF TITAN TRAILERS, ANY REPRODUCTION IN WHOLE OR PART IS STRICTLY PROHIBITED WITHOUT OUR WRITTEN CONSENT.

DRAWN BY	SCALE	DATE	DWG	REVISION
SCG	50	20-Jun-2022	AD-6944-01-V1	01

Titan Trailer Inc.

Trison Side Roll Tarp Form (West Coast Bungie)

Work Order #	6944	<u>Customer Name:</u>	OT Stock
Trailer Length	53 ft	<u>Dealer</u>	Ocean Trailer
<u>*Tarp colour*</u>	Black	<u>Width</u>	102" Nominal

Vinyl Mesh

<u>Cables & Bungie Location</u>	<u>Roadside</u>	<input checked="" type="checkbox"/>	or	<u>Curbside</u>	
Tarp Stops Style-Standard	Yes	Qty			
Easy off Flexible 6" Offset tarp stop	<input checked="" type="checkbox"/>	<input type="text" value="8"/>			
Optional					
Easy off Flexible 3" Offset tarp stop	<input type="text"/>	<input type="text"/>			
Tarp Headers					
Flat Front	<input checked="" type="checkbox"/>				
Flat Rear	<input checked="" type="checkbox"/>				
4" Rise Front	<input type="text"/>				
4" Rise Rear	<input type="text"/>				
9" Rise Front	<input type="text"/>				
9" Rise Rear	<input type="text"/>				

* Add special 2 to 1 pull rope to tarp

	Yes	No		Qty
<i>Ratchets & Cables 5pcs Std.</i>	<input type="text"/>	<input checked="" type="checkbox"/>		<input type="text" value="5"/>

If no see note below

Trison to install (1) Chain & binder front & rear with (5) cables & West Coast Bungees evenly spaced between. Titan to install tarp hooks, as well as UHMW pads at the joint of each cable and bungee before going to Trison. **Trison to add Rubber Wind deflector to front. Titan to provide storage for crank handle.**

	Yes	No		Qty
Drain holes Required	<input checked="" type="checkbox"/>	<input type="text"/>		<input type="text" value="12"/>

Note: Location of drain holes will be determined by the trailer design. Std size is 2" x 2" mesh

Tarp Crank location	Front	Ground		Catwalk		Rear	
at	<input checked="" type="checkbox"/>	from	<input type="text"/>	or	<input checked="" type="checkbox"/>	or from	<input type="text"/>

Tarp Crank length will be determined by location

ADDITIONAL NOTES.

Trison to Add Rubber wind Deflector to Front

Please complete sign, date and fax back to 519-688-3083

Customer Signature		Date	
--------------------	--	------	--