



Quote 03-Aug-23  
 New Order 04-Aug-23  
**FINAL**

**35-3ATWDP OT External Hoist, Level - POLISHED PANELS** Ref# **6889**

Revision

**CUSTOMER APPLICATION**

**AGGREGATE - POLISHED PANELS**

W/O# 7173

**S.P.I.F. 1 - Single / Tandem / Tridem**

DATE: 17-Aug-23

**SINGLE SEMI-TRAILER**

Designation

**ORDER STATUS** Final to approve

CUSTOMER NAME	<b>OT Stock - Gravel Spec</b>	PO	95366-95370	File	
ADDRESS		DRAWING#	<b>AD-7177-01-V1</b>		
CITY		CONTACT			
PROV/PC STATE/ZIP		DEALER	<b>Ocean Trailer</b>		
PHONE		SHIP VIA	<b>FOB Delhi, ON</b>		
FAX		SALESMAN	<b>Will Tucker</b>		

Is Vehicle Permitted? Yes or No

What is the combined Gross Vehicle Weight?

**Qty = 5**

(MAY CHANGE, MUST BE CONFIRMED AT TIME OF ORDER)

SERIAL NUMBER/S	<b>PG 3</b>				PRICING
BASE MODEL	<b>35-3ATWDP OT External Hoist, Level - POLISHED PANELS</b>				
OVERALL LENGTH	<b>35'</b>	OVERALL WIDTH	<b>102" NOMINAL</b>		
FRONT HEIGHT	<b>12" rise</b>	TAILGATE HEIGHT	<b>TO SUIT SIDEWALLS</b>		
BOX LENGTH	<b>34 FT 6 IN</b>				
FRONT FRAME EXT	<b>6"</b>				
KING PIN LOCATION	<b>24" from front of Trailer(Bolt-In)</b>				
UPPER COUPLER	<b>3/8" Thk Aluminum with Steel Overlay - Set at 48"</b>				
HOIST	MAKE	Stroke	FEE-8-5-269	Style	External
SLIDER BOX/BOGIE	<b>N/A</b>				
	PRIMARY	LIFT or STEERS			
NUMBER OF AXLES	<b>3</b>				
AXLES	<b>Intraax Straight Spindle - Note 7</b>				
AXLE TRACK	<b>77"</b>				
SUSPENSION	<b>Intraax AAT30K</b>				
LOCATION OF SPREADS	<b>see axle layout</b>				
HUB / DRUM ASSEMBLY	<b>10 Stud Cast - Cast Drum</b>				
DISC WHEEL SIZE	<b>8.25 x 22.5</b>				
RIMS	<b>ALUM-LVL1-Inner/outer</b>				
TIRES	Brand	<b>Goodyear</b>			
	Size	<b>11R22.5 - 41.9 dia</b>			
	Tread	<b>Endurance RSA</b>			
	Ply	<b>14</b>			
	Quantity	<b>12</b>			
TAILGATE	Style	<b>Sloped - 5 degree STD.</b>			
	Type	<b>Dump Style</b>			
	Material	<b>2 1/2" M.D. Panel</b>			
AXLE LAYOUT	<b>FRONT -Prim-60-Prim-60-Prim-27-REAR</b>				Sub(1)

35-3ATWDP OT External Hoist, Level - POLISHED PANELS		Ref#	6889	Pg.2	
CUSTOMER NAME:		OT Stock - Gravel Spec		PG 3	W/O # 7173
TITAN SALES #		PO 95366-95370	S/N		
			Note#	PRICING	
OIL SEALS		To suit axles			
LUBRICANTS		Oil-Std 80W-90			
BRAKES	ABS	2S2M			
	Slack Adj.	Haldex Auto			
	Cam Enclos	All Axles - c/w Dust Shields			
LIFT KITS		None			
LIFT CONTROLS		None			
FRAME WIDTH		48"			
BEAMS	Flange Bottom	3/4" x 6" (Aluminum I-Beam)			
	Flange Top	6" with Rubber Insert Channel (Aluminum I-Beam)			
	Web	3/8" (Aluminum I-Beam)			
NECK Length	K.P. -Transiston	70" (Seventy)			
REAR BUMPER		None			
TIRE CARRIER		None			
LANDING GEAR		Jost Ax150.G1.19 Aluminum landing gear-5year maint free, 10 year warranty			
FENDERS		None			
EXTENDED NECK FENDERS		None		2	
SIDE MATERIAL/HEIGHT		NGHD Panel, 58" (50" Solid Inside, 8" Board)			
TOP RAIL		New Dump Style			
SIDE WEAR PLATE (Triangular)		None			
FLOOR		2 1/2" Panel			
FLOOR WEAR PLATE		None			
SEALED GATE		Rubber			
COAL CHUTE		None			
WINDERS		SS Winders, 2 Bottom, No winder holders to be installed on rear door			
TAILGATE LATCHING		Air Operated			
HOIST		External		4	
TARP SECUREMENT		None			
BODY HOLD DOWN		Titan			
TARP SYSTEM		Trison Electric Mesh front to back Cable system		4	
TOOL BOX		None			
HYD FITTING	Pressure	1" Wing- Male #5100-S2-16B			
	Return	N/A			
MUD FLAPS	Style	Titan Black Rubber			
	Location	1set ahead of primary and 1 pair Titan flaps with center plain black flap at rear			
MUD FLAPS - Landing Gear		4 mudflaps at landing gear			
PAINT (See Form)	Body- Color	Flat front style - POLISHED PANELS			
	Frame	Natural aluminum			
	Hub / Drum	Titan Black - DO NOT PAINT INTRAAX AXLES WITH GALVANIZED HANGERS		7	
	Rims or Disc	Aluminum			
LIGHT PACKAGE (Plug Form)		Front-(1) mkr per side high-(3) mkr (includes midturn)-rear (3) S/T/T per side (3) 4" Round center in lightbar		3	
ADDITIONAL LIGHTS' OPTION #1		Add 6 Markers per side = 9 total spaced evenly along the bottom			
ADDITIONAL LIGHTS' OPTION #2		None			
ACCESS	Front - Outside	None			
	Front - Inside	None			
	Rear - Outside	4 Titan cast steps, installed Roadside			
	Rear - Inside	1 step, installed Roadside just above the liner			
				Sub(2)	

CUSTOMER NAME:

OT Stock - Gravel Spec

TITAN SALES #

PO 95366-95370 S/N

PG 3

W/O# 7173

**ADDITIONAL SPECIFICATIONS**

Note#

PRICING

1) 4" liquid load Gauge on RS on the face of chassis web.

2) Hinged cover plate over gooseneck

3) Add an additional pair of 4" Round LED lights to make 5 - 4" round in center

4) Trailer front end designed to work with Trison Electric front to back Mesh Cable Tarp system.

5) Add spreader chains Ref 6889

6) Trison installed UHMW 12' wide liner 24.5' - 3/8 THK, 10' - 1/2" THK.

7) Intraax Primaries to be on Galvanized Hangers with black soft coat

8) Switch gladhand and tarp plug so that gladhands are on either side of the main plug

**9) Cab controlled electric over air to open tailgate - needs to be discussed and is not priced (Bryan B)**

OTR #

VIN#

95366

2TVDP3532RD000823

95367

2TVDP3534RD000824

95368

2TVDP3536RD000825

95369

2TVDP3538RD000826

96370

2TVDP353XRD000827

Any applicable Taxes are the responsibility of the customer

DATE: 17-Aug-23

SUBMITTED BY

Customer

[Redacted]

SK 8/9/23 (LB)

[Redacted]

Date

Sub Total (3)

Sub Total (2)

Sub Total (1)

TOTAL PRICE PER UNIT

TOTAL COST

Trailers are sold FOB Delhi, Canada

CAD\$

# TITAN TRAILERS

## PAINT COLOUR & CODE FORM

<b>CUSTOMER</b>	<b>OT Stock - Gravel Spec</b>	<b>TITAN WORK ORDER #</b>	<b>7173</b>
<b>DEALER</b>	<b>Ocean Trailer</b>	<b>DEALER WORK ORDER #</b>	
<b>TRAILER TYPE</b>	<b>35-3ATWDP OT External Hoist, Level - POLISHED PANELS</b>		
	<b>PURCHASE ORDER #</b>	<b>95366-95370</b>	
	<b>UNITS IF APPLICABLE</b>	<b>5</b>	

	PAINT COLOUR	PRODUCT NAME	PAINT CODE
<b>Body</b>	Polished Panels	None	None
<b>Frame</b>	Natural aluminum	None	None
<b>Running Gear</b>	BLACK	Titan	None

Paint colours are Titan Red, Black or Silver please enter Titan under product name & no code is required.

### **POLISHED PANELS**

### **RUNNING GEAR: TITAN BLACK**

**\*\*\*DO NOT PAINT INTRAAX AXLES WITH GALVANIZED HANGERS, THEY HAVE ALREADY BEEN COATED BY HENDRICKSON WITH A BLACK SOFT COAT**

**\*IF Fully Painted, Thinwall trailers will be painted underneath same as frame & running gear\*  
& axles will not be painted prior to going to paint.**

All Thinwall Trailers that have Body left Natural will receive silver air tanks & silver upper couplers

\*Dealer or Customer must supply Titan Trailers with required paint codes, product name, colour and a

DRY sample of paint. All Two Toned Painted Trailers\* must have additional detailed written specifications entered above.

Paint Chip Required

**NO**

### **Complete Form in Full**

Dealer Signature

Date

Paint Information needed by this date

**\*Failure to meet this date will delay trailer completion\***

**TITAN TRAILERS WILL NOT BE RESPONSIBLE FOR INCORRECT PAINT SPECIFICATIONS**

Office Use Only

Trailer Sales Department

Date

Signature

# TITAN TRAILERS - TRAILER WIRING SCHEMATICS

## Wiring Specs

1129 Hwy #3, R.R. #3  
Delhi, Ontario  
Canada, N4B 2W6

Phone: 519-688-4826  
Fax: 519-688-3083  
[www.titantrailers.com](http://www.titantrailers.com)

35-3ATWDP OT External Hoist, Level - POLISHED PANELS

<b>Work Order</b>	7173
<b>P.O. #</b>	95366-95370
<b>Quantity</b>	5

<b>Customer</b>	OT Stock - Gravel Spec
<b>Dealer</b>	Ocean Trailer
<b>Dealer #</b>	

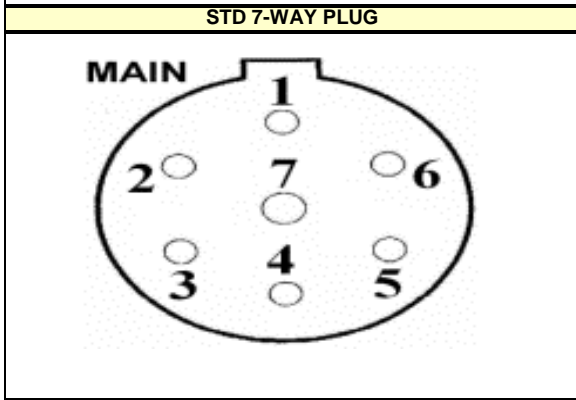

#	COLOUR	FUNCTION
1	WHITE	Ground
2	BLACK	Front/Rear CLS, I.D., Licence
3	YELLOW	Left Turn, Hazzard
4	RED	Stop Lamps
5	GREEN	Right Turn, Hazzard
6	BROWN	Side Markers, Tail Lights
7	BLUE	A.B.S. Power

#	COLOUR	FUNCTION
1	WHITE	
2	BLACK	
3	YELLOW	
4	RED	
5	GREEN	
6	BROWN	
7	BLUE	

STANDARD 7-WAY PLUG

I.S.O. 7-WAY PLUG

**Plug Information needed no later that the following date:**

Failure to meet this date will delay trailer completion.

**Dealer**

**Signature:**

**Date:**

**Date form returned:**

**Trailer Sales Initials:**

# CONFIGURATION APPROVAL DRAWING

THIS DRAWING CONFIRMS BASIC TRAILER DIMENSIONS; OVERALL HEIGHT, OVERALL LENGTH, PIN SETTING AND AXLE POSITIONS ONLY.  
TRAILER OPTIONS MUST BE VERIFIED BY REFERRING TO THE SALES ORDER. ANY DISCREPANCIES MUST BE REPORTED TO TITAN TRAILERS INC.

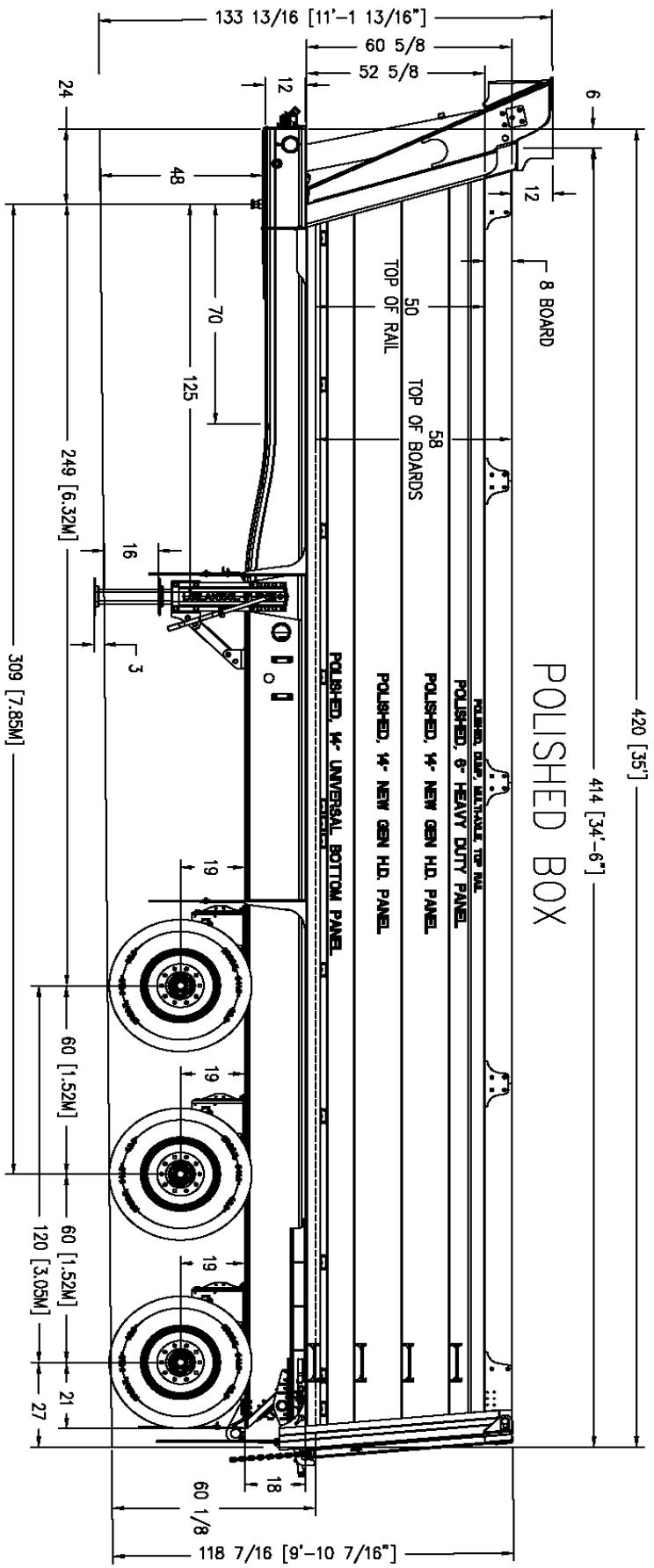

HOIST: HYVA FEE-8-5-269, 40 TON, 269" STROKE - 40° TIP ANGLE  
 SUSPENSIONS: HENDRICKSON INTRAAX AAT30K  
 TIRES: 11R22.5  
 LANDING GEAR: JOST AX150-G1-19 Aluminum Landing Gear  
 VOLUME: 1327 cu ft (49.2 cu yd)

INTRAAX  
 AAT30K-19  
 TRIDEM

NO NO 7173  
 DEALER NO

APPROVED BY: \_\_\_\_\_  
 SIGNATURE: \_\_\_\_\_  
 DATE: \_\_\_\_\_

CUSTOMER: OT Stock  
 TRAILER: ALUMINUM CHASSIS, EXTERNAL HOIST  
 35' 3-AXLE THINWALL DUMP  
 AGGREGATE APPLICATION

**TITAN TRAILERS INC.**  
 RR#3 DELHI, ONT  
 N4B 2W6

DEALER IS RESPONSIBLE TO CHECK THAT TRAILER CONFIGURATION SHOWN ON THIS DRAWING CONFORMS TO ALL PROVINCIAL, STATE AND/OR FEDERAL REGULATIONS. THIS DRAWING IS THE SOLE PROPERTY OF TITAN TRAILERS. ANY REPRODUCTION IN WHOLE OR PART IS STRICTLY PROHIBITED WITHOUT OUR WRITTEN CONSENT.

DRAWN BY: SCG  
 SCALE: 3/8"  
 DATE: 16-Aug-2023  
 DWG NO: AD-7173-01-V1  
 VERSION NO: 01